

**DIMENSIONES / DIMENSIONS / DIMENSIONS / DIMENSION (mm)**

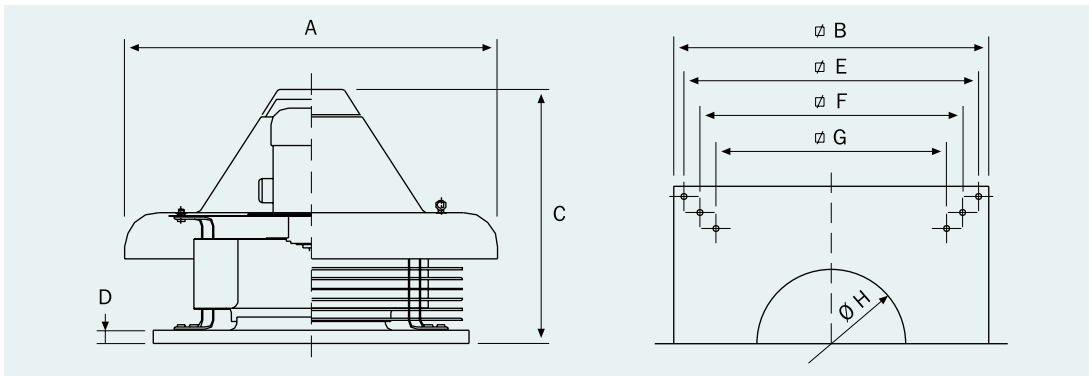

	A	$\varnothing B$	C	D	$\varnothing E$	$\varnothing F$	$\varnothing G$	$\varnothing H$	Kg
<b>CF 25</b>	560	440	475	38	385	-	-	185	15
<b>CF 31</b>	560	440	475	38	385	-	-	220	16
<b>CF 35</b>	800	500	530	38	437	-	-	270	25
<b>CF 40</b>	800	500	580	38	437	530	471	296	30
<b>CF 45</b>	800	650	617	38	600	530	471	296	38
<b>CF 56</b>	800	760	775	38	710	650	550	398	57
<b>CF 63</b>	1100	930	905	38	870	775	665	439	75
<b>CF 71</b>	1100	930	955	38	870	775	665	484	94
<b>CF 80</b>	1100	930	995	38	870	775	665	515	132

**CURVAS CARACTERÍSTICAS / PERFORMANCE DATA / COURBES CARACTÉRISTIQUES / KENNLINIEN**

**CF 1400 RPM**

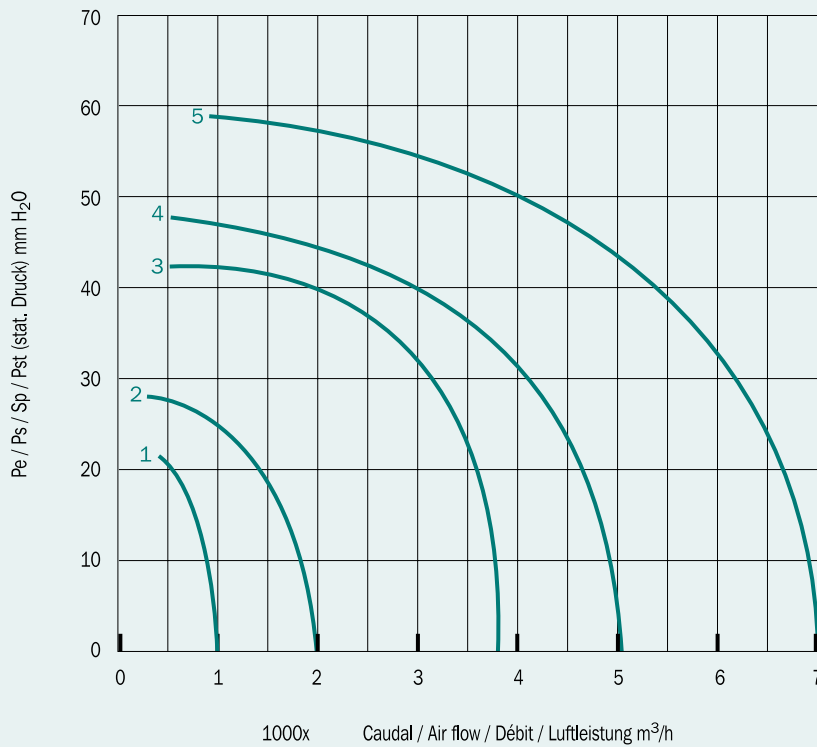

- 1. CF 25 (0,12)\*
- 2. CF 31 (0,18)\*
- 3. CF 35 (0,25)\*
- 4. CF 40 (0,37)\*
- 5. CF 45 (1,10)\*

\* Kw

**CURVAS CARACTERÍSTICAS / PERFORMANCE DATA / COURBES CARACTÉRISTIQUES / KENNLINIEN**

**CF 700 RPM**

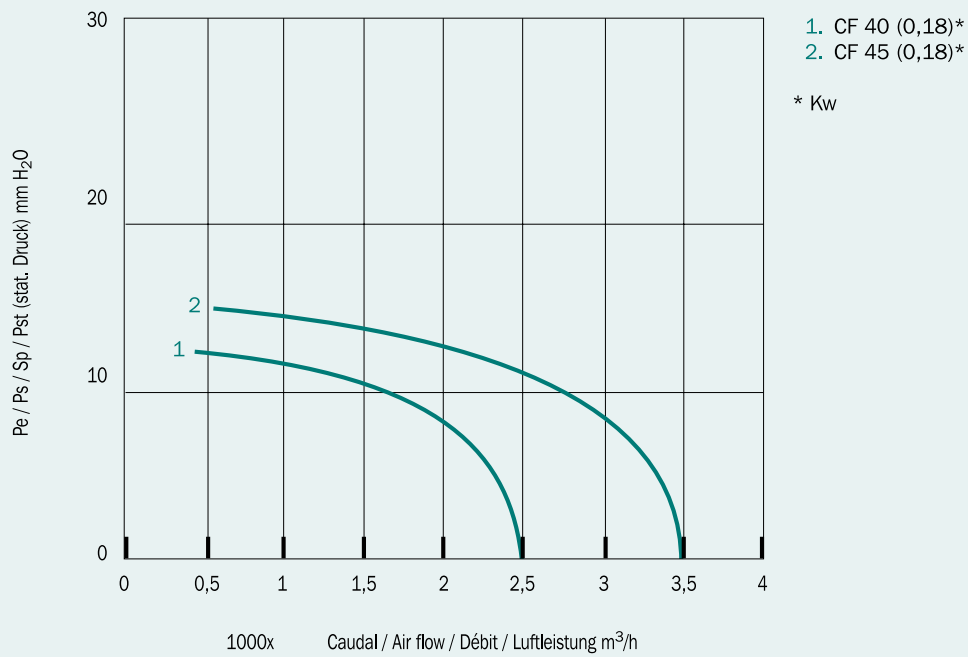

**CF 700 RPM**

